

**Urgent meeting, BSCA Tokyo 19, May (THU), 2011**

**Rebuild Japan: Future Energy and Commissioning**

**—Discussion on the strategy and framework of building energy system and energy conservation based on the Commissioning after the East-Japan Big Earthquake Disaster**

**BSCA Cx qualification, Statements for future HVAC and energy systems**

## **BSCA Qualification of Professional Engineers for Commissioning Business**

**N. Matsuda (CxPE, BSCA director)**

**N. Nakahara (CxPE, BSCA chairman)**

---

# Overview

- Role of commissioning at the revival from the Eastern-Japan great earthquake
  - Problems confronting propagation of commissioning business in Japan and establishing training course for qualification of commissioning professionals.
  - BSCA's commissioning qualification system, the way of thinking
  - Overview of the activity towards establishing qualification system and training program
  - Flowchart of authorization and certification of commissioning professionals of BSCA's
  - Viewing future efforts and schedule
-

---

## Role of commissioning at the revival from the Eastern-Japan great earthquake

- The constraints on energy supply and demand given by the BIG DISASTER and subjects to be discussed
    - Given the constraints due to nuclear power plant accident;
    - The long run strategies: Promotion of the stabilization, diversification of the energy source together with promotion of natural energy use
    - The short run strategies: The increase in energy efficiency of energy use, load leveling and energy saving using various measures
  - At the rim of energy crisis due to the power plant damages, it is necessary to urgently promote energy saving and raising energy efficiency as well.
    - ① The commissioning process shall be applied to newly built buildings to clarify design requirements concerning energy efficiency and functional performance.
    - ② It is important to apply a retro commissioning process to existing buildings and following continual commissioning with a lifecycle view.
  - Upbringing of technical experts to manage commissioning process, develop and handle commissioning tools in order to implement the commissioning procedures effectively and skillfully.
-

# The construction and the operation of the facilities and the commissioning

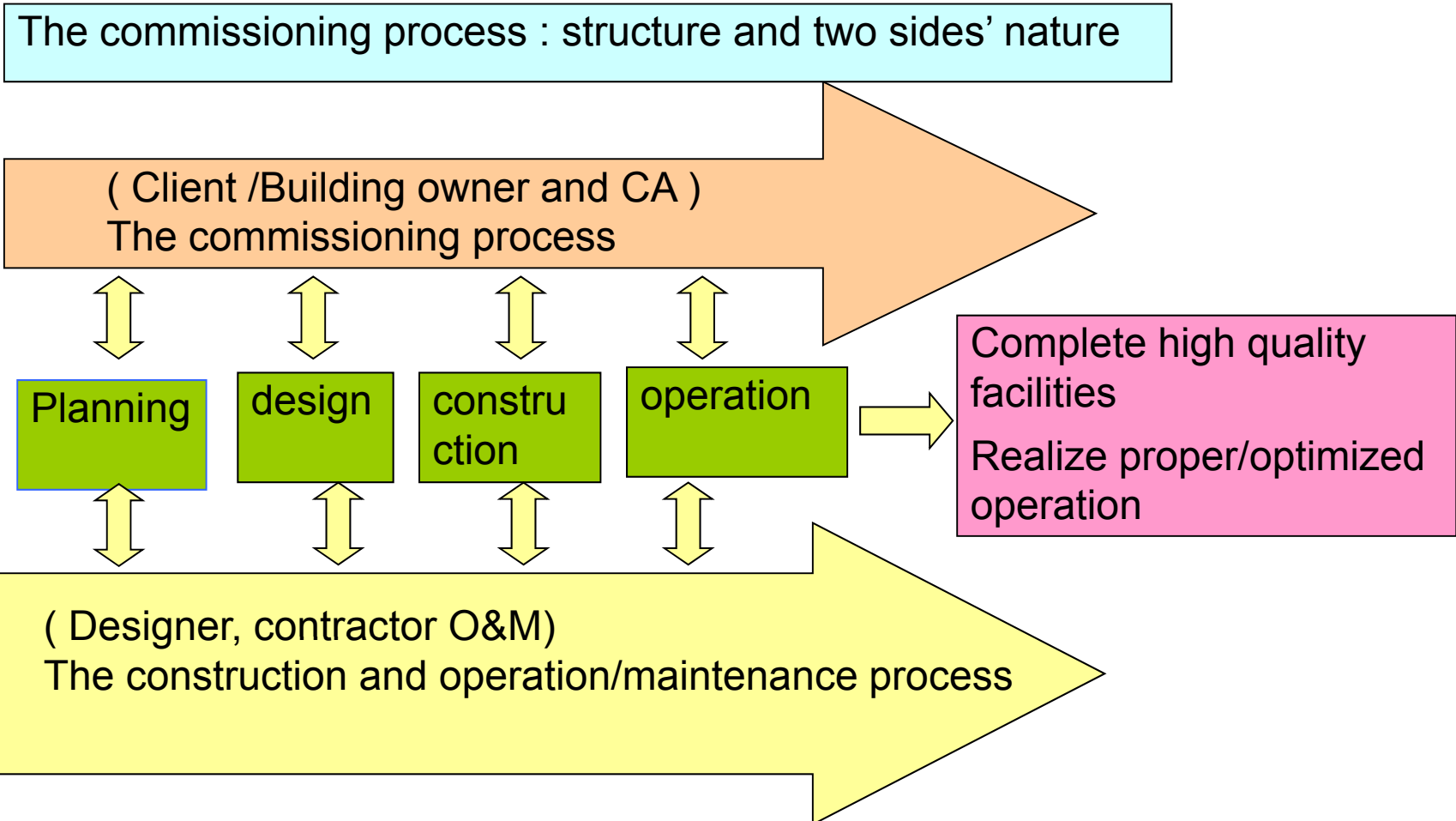

The commissioning ranges over the life cycle of the facilities from the building plan, design and construction to operation and maintenance, and aims at increasing efficiency of energy use and optimizing maintenance and facility performance .

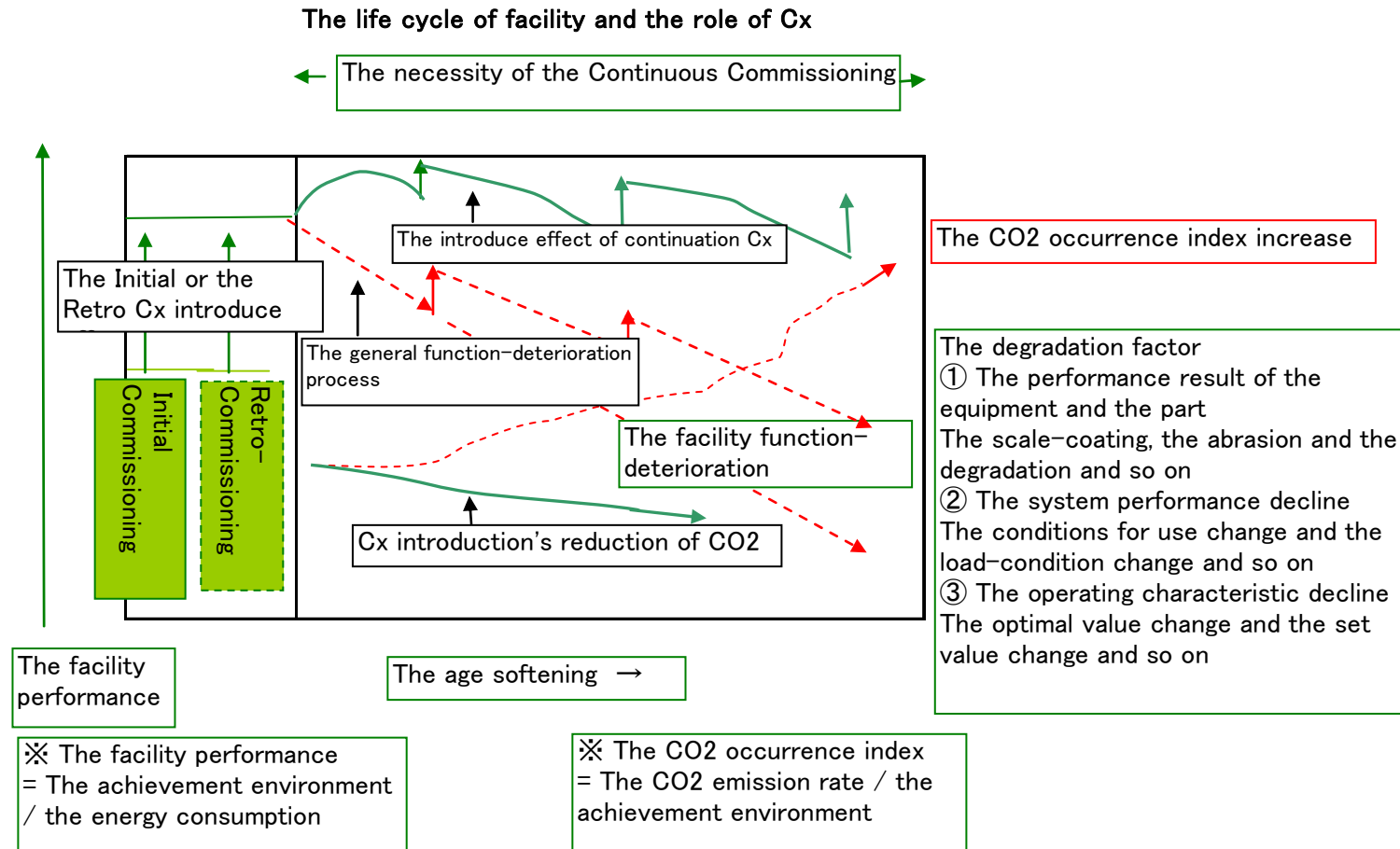

---

- **Creating commissioning market and the role of BSCA**

→ **Promote to establish infrastructure of commissioning business**

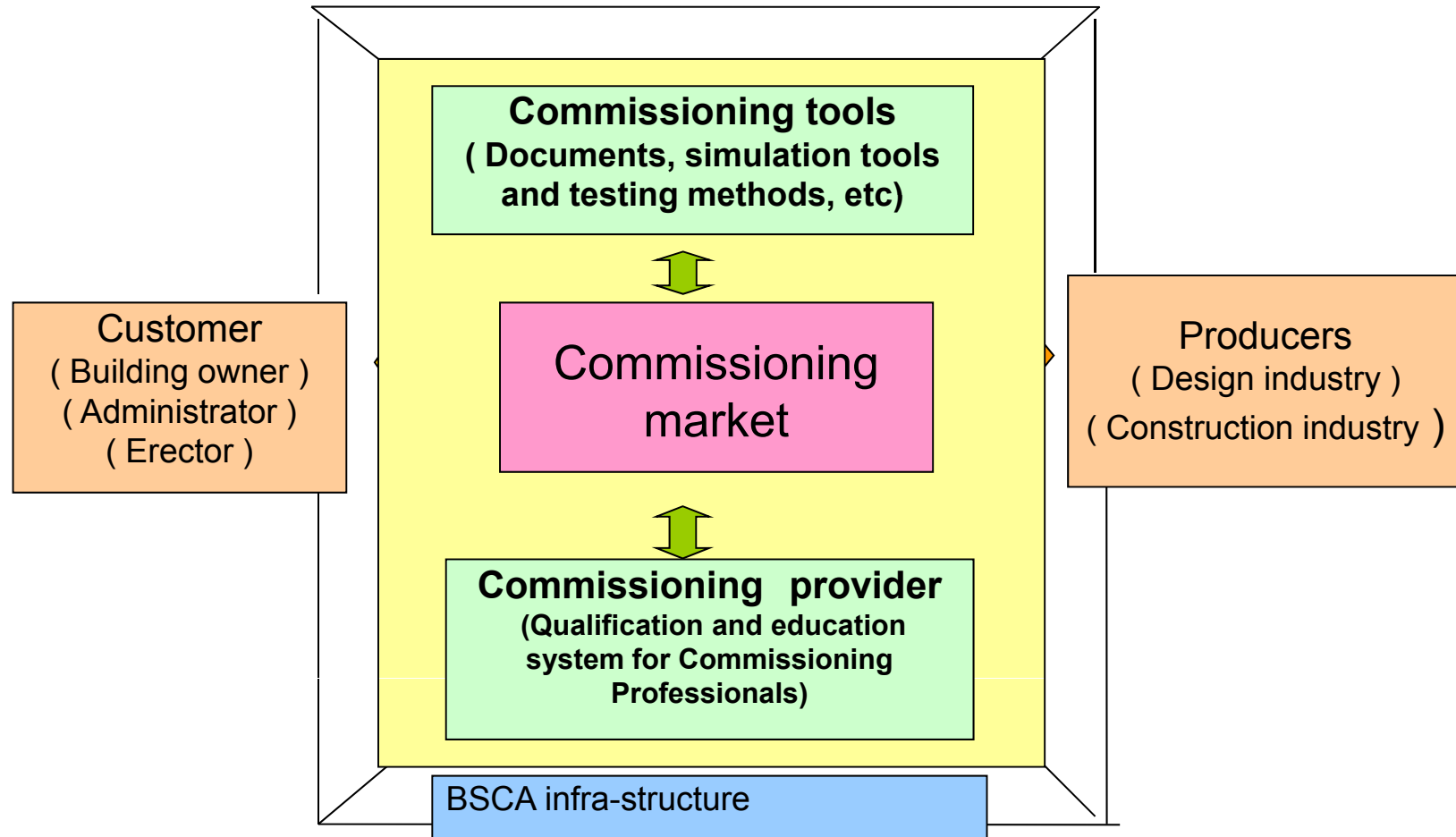

---

## Activity of BSCA to propagate commissioning process

- **1. The understanding promotion of the person concerned ( the owner and so on )**
    - Holding lecture meetings and opening homepage, etc.
    - Achieving actual commissioning results
  - **2. Developing and servicing Cx tools and the technical standards**
    - Commissioning guideline, testing guideline (together with SHASE committee)
      - Retro commissioning process guideline
      - Functional performance testing guide
      - TAS (testing ,adjusting and start up) guide
    - Creating practical tools and manuals
      - Commissioning manual
      - Technical and/or data analyzing tools
  - **3. Upbringing Cx professionals as business providers (CxPE, CxTE)**
    - Establishing Cx qualification system  
with role sharing between SHASE and BSCA
    - Upbringing human resources and issuing certification
-

## Principal works done by Cx engineers relating to Cx phases

division	Program phase	Design phase	Construction phase	Operation phase
Role of Cx engineers	Establish OPR, Draft Cx plan, Support the owner in reviewing design proposal	Review and verify if the design documents satisfy OPR, Update Cx plan.	Review and verify if construction process Develops to satisfy the Performance defined in OPR and if the system could be accepted.	Finalizing Cx process Seasonal testing and data analysis, BOFDD and optimizing operation
Principal works and required Quality for Cx engineers	Manage Cx meeting, Propose Cx works, Create OPR and Cx plan, Support the owner In creating master Plan, issuing RFP_DP and reviewing design proposals	Manage Cx meeting, Verify DP's check and review process, Review and verify design tools, design documentation, basis Of design and design documets, Create Cx. Spec., Update Cx plan, Submit Cx progress report	Manage Cx meeting, Review and verify -construction plan -construction documents -TAS plan -prefunctional checklist -lead functional performance testing -manage O&M's training /education -system manual documentation Submit Cx progress Report	Seasonal functional performance testing Data analysis and performance Evaluation Parameter tuning and optimization Verify yearly energy / environmental performance Finalizing Cx process and submit final Cx report

---

## The Required capability for Cx professional engineers and qualification

- BSCA's way of thinking about qualification for Cx engineers
    1. To have correct knowledge of Cx process / management and qualified capability to execute commissioning process
      - It shall be sufficed by lectures, discussions, self-study and examination at the end of lectures. To pass a training course is recommended but no facility has been established in Japan yet.
    2. The professional engineering knowledge for commissioned system and building is necessary.
      - The academic education carrier together with professional business career shall indirectly certify the capability for qualification.
  - BSCA's three days course of study and training for CxPE, commissioning professional engineer, copes with the first item above mentioned for qualification.
-

---

## Problems of human resource for Cx process and study course

- Building services systems are divided into HVAC, electricity, sanitary and control systems, etc., to be called as BE hereafter. Moreover, each BE in the course of production includes program, design, construction and operation phases, to be called as PH hereafter. Engineers who are well experienced with all PHs even for a single kind of BE are rarely found.
  - The commissioning process shall be implemented by commissioning management team that consists of commissioning authority who directs the team and manages the whole process and several professional engineers and technicians engaged in each BE and PH according to the scale and the degree of complexity of the commissioned facility.
  - The qualification system and the study and training program must correspond with these characteristics of Cx process management and team composition.
-

# The BSCA qualification system

- CA, Commissioning Authority

When the CxAC, sometimes even CxPE, is actually hired for a specific commissioning project with the quality of third party concerning the design and construction of the project, he shall be called as commissioning authority, CA. It is of course the engineering and managerial capability corresponding to the project scale and complexity shall be sufficed.

- CxAC, Commissioning Authority Candidate

When a CxPE is qualified as having sufficient capability to work as CA, who shall have professional knowledge and experience of more than one BEs and / or PHs each and qualified by the BSCA program, he shall be called as commissioning authority candidate.

- Commissioning Professional Engineer(CxPE [BE/PH])

When a engineer passed the examination after the CxPE study and training course and was verified as qualified for academic carrier and professional experience, he shall be qualified as commissioning professional engineer, CxPE, for specific field of Be(s) and PH(s).

BE: HVAC, PS (Plumbing and Sanitary), LE (Lighting and Electricity, BEMS (BEMS, BOFD and/or Controls)

PH: Des (Design), Cons(Construction and Supervision), Ope (Operation and Maintenance )

- Commissioning Technical Engineer (CxTE)

CxTE\_A The test and inspection area

CxTE\_B Performance prediction and/or BOFDD using simulation tools

CxTE\_C The energy performance diagnosis area in liaison with other public organizations

---

# Composition of Cx Managing Team (CMT)

--composition example of the large-scale project--

▪

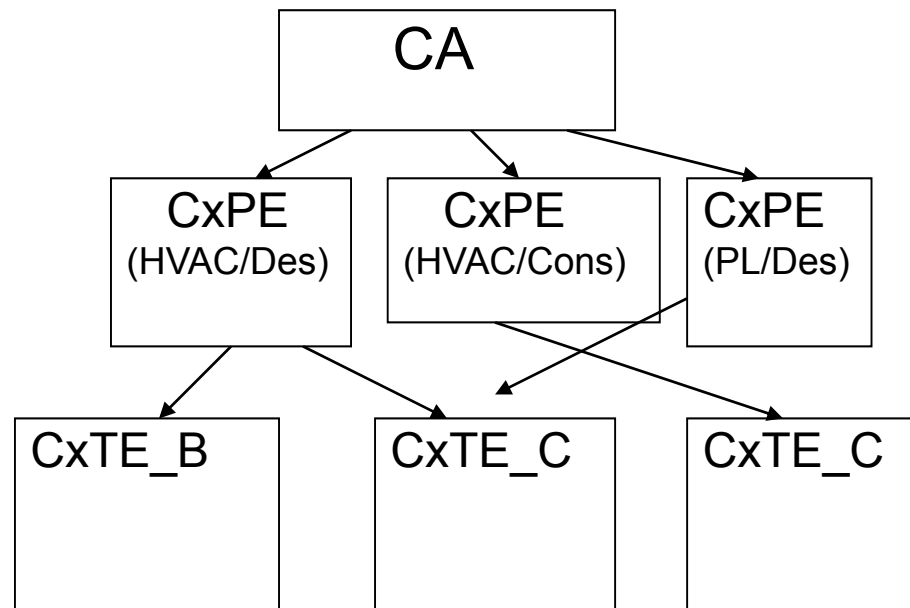

# Overview of the activity towards establishing qualification system and training program

phase repartition	period	activity overview	result or the discussion contents
Phase 1 investigation	2004 - 2006	Research of the qualification and training system in the U.S.A. Consideration on how to establish Japanese Cx qualification	Qualification system of NEEB, AABC, AEE, BCA and Wisconsin University were investigated. Qualification system implemented by SHASE, BELCA, JFMA, etc. were surveyed
Phase 2 preparation	May, 2006 - July, 2007	Discussion and drafting of qualification system and training course	Discussion on qualification requirements such as professional experience and academic degree.
	July, 2007 - October, 2007	Initiate drafting the text for qualification lecture courses.	Discussion on the practical use of SHASE Cx Guideline and role sharing with the BSCA Cx textbook to be drafted.
	October, 2007 - December, 2008	The open discussion of the qualification system and the original version of Cx textbook and qualification system drafted	Promotion of drafting text by the working group Holding qualification workshops open to the public in Tokyo and Nagoya.
	January, 2009 - July, 2009	The completion of the original version of the textbook to be called as BSCA Commissioning Manual hereafter, and holding review meeting	Planning a model course of CxPE lecture course as trial. Group discussion of the Cx manual for actual implementation of lectures.

phase repartition	period	activity overview	result or the discussion contents
Phase 3 start-up	July, 2009 - May, 2010	Trial study and training for the first qualification was planned and implemented	<p>Qualification implementing committee was established and trial CxPE qualification course was planned and implemented.</p> <p>Commissioning manual was finally reviewed and published for trial course.</p> <p>Trial training program was elaborated and participants for model trial were selected at the committee and invited.</p> <p>The trial course was performed at the BSCA head office in Ikeshita, Nagoya. Ten engineers were awarded as the first certified CxPE .</p>
Phase 4 operation	June, 2010 - November, 2010	Promotion of steady operation of qualification, for member BSCA as the second step	<p>Apart from the manual, textbook was proposed to create for the convenience of lectures and the drafting and reviewing works done. The second CxPE training course limited to member BSCA was planned and implemented in order to steady BSCA qualification system in Nagoya again. Five engineers were certified as CxPE.</p> <p>Workshops to publicize BSCA qualification, were held in Tokyo, Nagoya, Oosaka and Fukuoka with the subsidy of Japan Architectural Education and Information Center.</p>
	November, 2010 –March, 2011	Trial training course open to the public for normalizing qualification	<p>CxPE training course open to the public was held in Tokyo in March, 2011, for the third time. A participant joined from Shanghai, China. Seven engineers were certified as CxPE.</p> <p>· Second edition of Cx Manual and textbook was published</p>
Phase 5 Development	Fiscal 2011 -	Further develop Cx qualifying training courses	<p>Qualification of CxTE, commissioning technical engineer, will be discussed and workshops will be held in several cities.</p> <p>CPD, or the step-up system of the CxPE will be studied for qualifying CxAC, Commissioning Authority</p>



# The overview of the study and training material

The composition and the background of the study and training teaching materials

The study and training text

The teaching aid

Questions

BSCA The commissioning manual of the Building Services System

PECI (Portland Energy Conservation, Inc.) Model Commissioning and Guide Specification

BSCA research and survey reports  
Model documents from actual commissioning process reports

SHASE Cx committee's reports and discussion materials

SHASE Guideline / manuals for

- Cx process
- Energy measurement
- The environmental measurement

ASHRAE STANDARD Cx guidelines 1996~2007

Research reports and meeting reports of international and domestic committees such as IEA, NCBC, etc.

# BSCA study and training text and commissioning manual



---

## Table contents of BSCA commissioning manual for Building Services Systems

- **Forward**
  - **Introduction**
  - **Chapter 1 Building Services System and commissioning**
  - **Chapter 2 Overview of the commissioning works**
  - **Chapter 3 Commissioning process of new building systems**
  - **Chapter 4 Commissioning process of existing building systems**
  - **Chapter 5 Continual Commissioning of building systems**
  - **Chapter 6 Overview and the utilization of simulation tools**
  - **Chapter 7 MQC for commissioning management and data base**
  - **Chapter 8 Standard documents and overview**
  - **Appendix List of referencing documents**
-

## Qualification requirement of CxPE and CxAC

Requirement	CA, CxAC	CxPE[BE/PH]
character of qualification	who manages the performance of the project as the leader of the commissioning managing team	who works in the commissioning managing team under the CA, engaged in performance management for the designated qualified BE/PH system(s) and phase(s)
academic background	who graduated from undergraduate course of scientific / engineering department of 4-year university and alike or above, or, who has been qualified as CxPE	who graduated from undergraduate course of scientific / engineering department of 4-year university and alike or above, or, who graduated from technical high school or graduated from non-science / engineering department of university but has more than 20 years of practical business carrier.

The requirement	CA, CxAC	CxPE[BE/PH]
business experience	<p>Concerning to the building services system of the present interest ,required engineering experience is;</p> <p>1. More than five years of each, but fifteen years in total, practical experience on more than two kinds of works among owner’s program, design, construction, construction supervision and, testing- adjusting-start-ups or actual operation data analyses/evaluation, or</p> <p>2 . Qualified for more than two kind s of phases of CxPE with more than five years of practical experience on commissioning works.</p>	<p>Concerning to the building services System of the present interest, required engineering experience is more than five years of each, but ten years in total, practical experience on more than two kinds of works among owner’s program, design, construction, construction supervision and, testing-adjusting-start ups or actual operation data analyses/evaluation.</p>
acquired qualification	<p>Who is qualified for more than two kinds of qualification concerning the professional engineering concerned.</p> <ul style="list-style-type: none"> <li>- Qualified first class architect /engineer for the building services engineering system (setsubi sekkei ikkyuu kentikushi)</li> <li>- Qualified professional engineer for building services engineering (kenchiku-setsubishi)</li> <li>- Qualified professional engineer (gijutsushi) relating to building services engineering (HVAC, electric)</li> <li>- Qualified energy manager</li> <li>- Qualified first class construction engineer (ikkyuu sekou kanrishi) for either plumbing engineering or electrical engineering</li> </ul>	Ditto (left)

CxPE  
engineer

Examination,  
Certification,  
Registration  
and  
Publication

**Certification and registration**

**1) Attending the training course and obtaining the certificate of completion**

**Who attended the study and training course for BSCA qualification and passed the examination shall have the certificate of completion .**

**2) Certification and registration**

**· Who obtained certificate of completion and wish to be qualified as CxAC will submit application for CxAC certification using the forms designated by BSCA and a copy of certificate of completion.**

**· Who already has more than two phases of CxPE and wish to be qualified as CxAC will submit application for CxAC certification using the forms designated by BSCA and a copy of certificate of completion.**

**· Who was judged to deserve the CxAC at the Certification committee should be qualified as CxAC are given BSCA certification of registered CxAC is registered as BSCA commissioning authority candidate.**

**3) Publication of qualified fact**

**The registered BSCA CxAC will be publicized On the BSCA home-page.**

**Certification and registration**

**1) Attending the training course and Obtaining the certificate of completion**

**Who attended the study and training course for BSCA qualification and passed the examination shall have the certificate of completion .**

**2) Certification and registration**

**Who obtained certificate of completion And wish to be qualified as CxPE will Submit application for CxPE certification using the forms designated by BSCA and a copy of certificate of completion.**

**2) Who was judged to deserve the CxPE at the certification committee should be qualified as CxPE are given BSCA certification of registered CxPE is registered as BSCA commissioning professional engineer.**

**3) Publication of qualified fact**

**The registered BSCA CxAC will be publicized on the BSCA home-page.**

# Qualification system of BSCA

General meeting

Board of directors

Qualification implementation committee.

Study and training course program  
(Lecture, discussion, examination)

The certification committee  
(represented by qualification  
implementation committee)

lecturer group

secretariat

The training lectures  
and workshops

## Flowchart of authorization and certification of commissioning professionals of BSCA's (1/2)

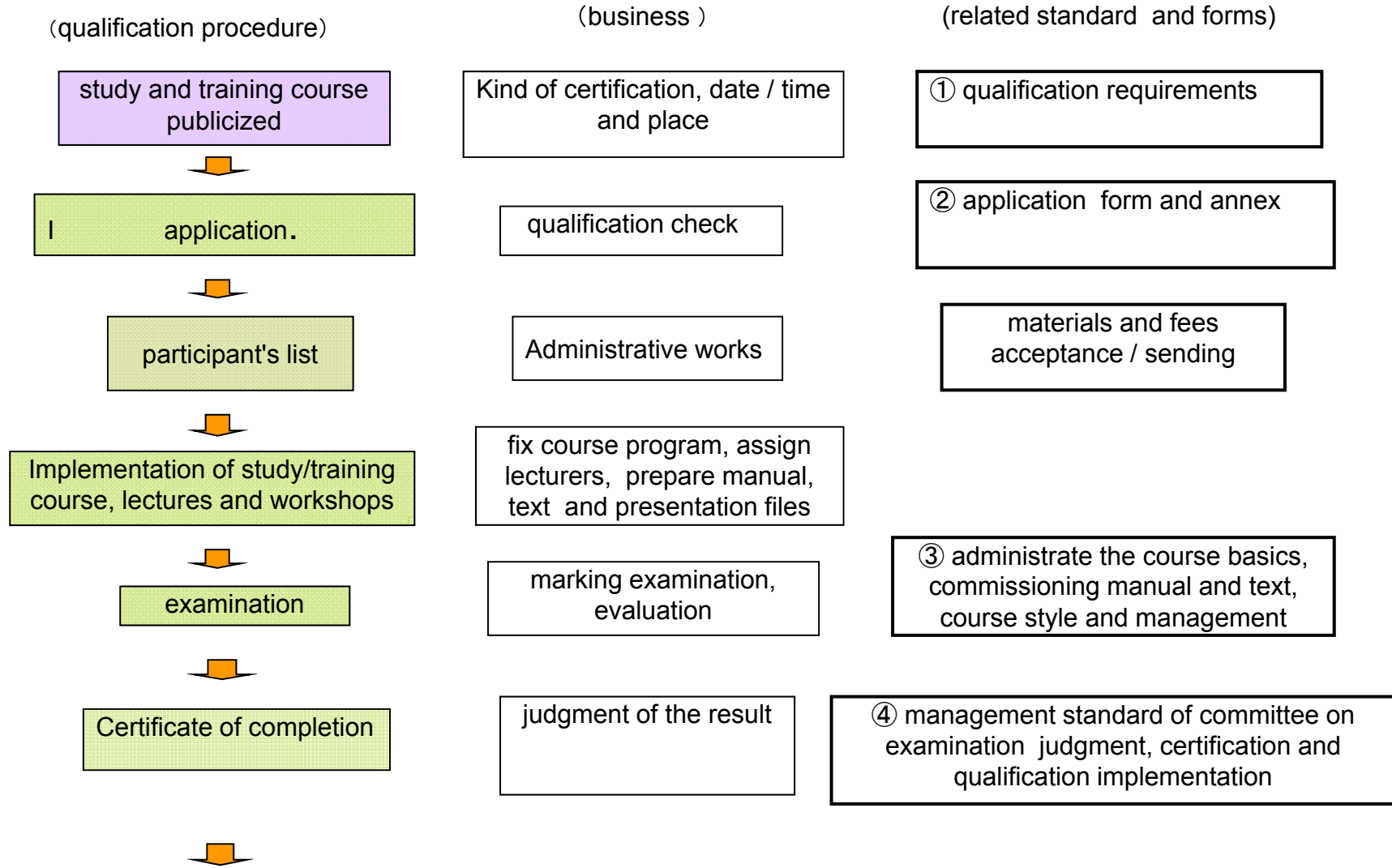

## Flowchart of authorization and certification of commissioning professionals of BSCA's (2/2)

(qualification procedure )

(business )

(related standard and forms)

From the previous page

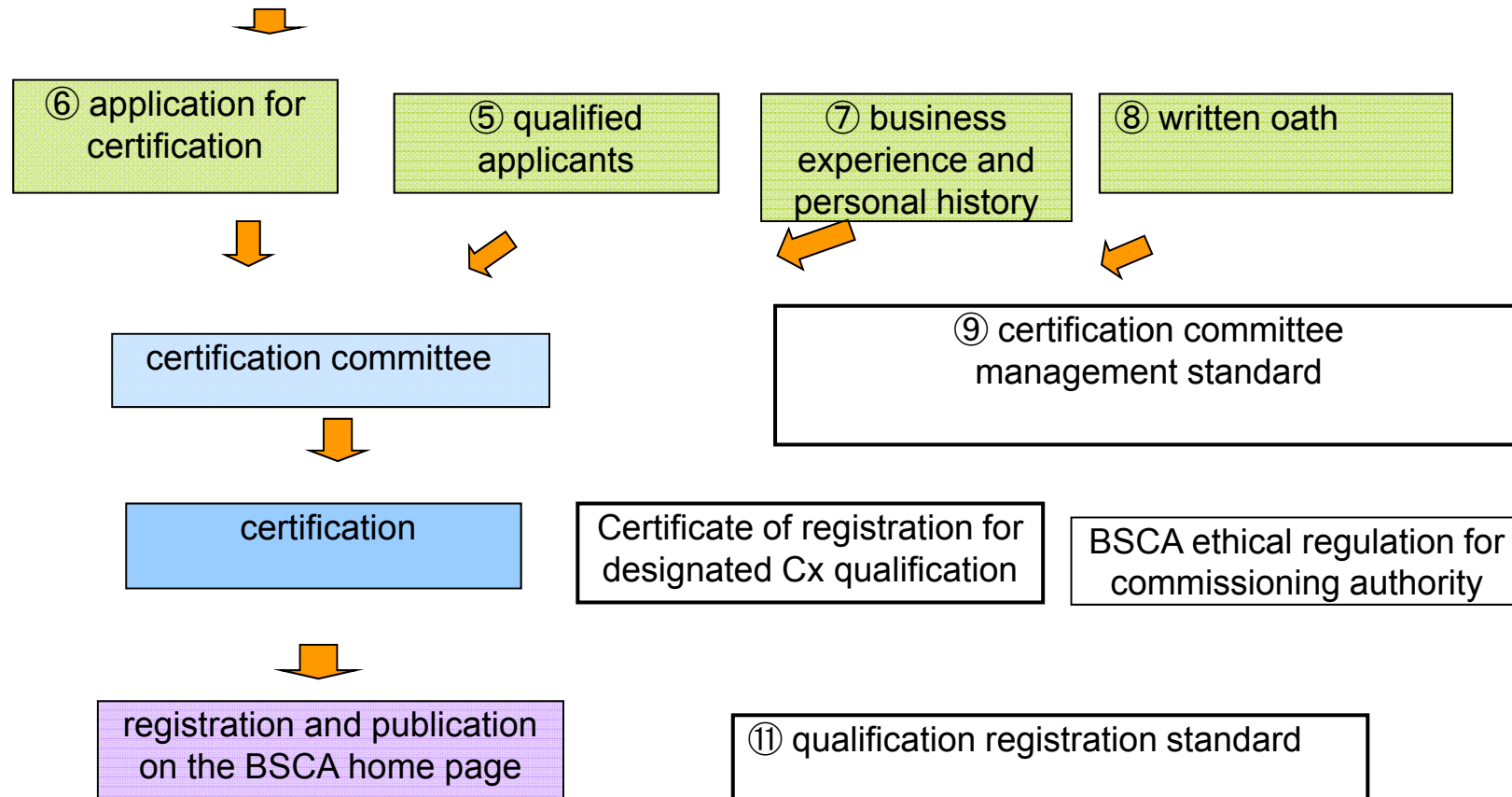

---

## Viewing future efforts and schedule

- Steady run for CxPE training course open to the public(the 2nd )
  - Review for the step-up program of CxPE to CxAC and CPD
  - Discuss implementation of CxTE qualification
    - Reexamination of the CxTE system
    - Drafting of a study and training plan
    - Creating texts for study and training course
  - Implementation of trial CxTE course with workshop and the authentication activity
-